

SW-PRO/SWS No blockage cutting type



SW-PRO



SWS

Model definition

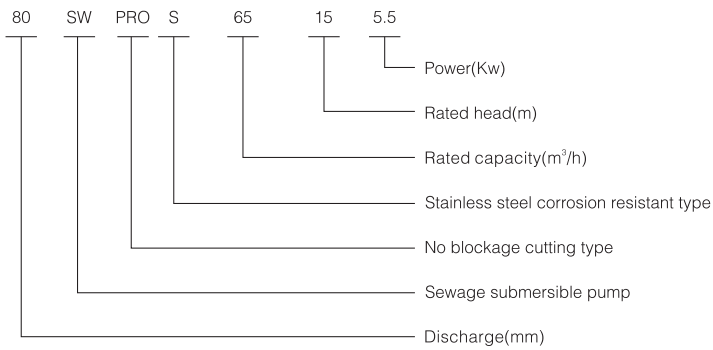

Structure drawing of 2pole motor

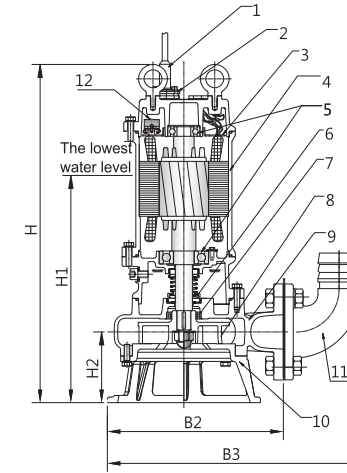

Construction and material of SW-PRO cast iron pump

No.	Spare part	Material	No.	Spare part	Material
1	Cable	YZW	7	Oil seal	NBR
2	Cable gland	304	8	Impeller	QT600
3	Threading plate	PA66	9	Pump casing	HT200
4	Motor	Shell HT200	10	Basement	QT600
5	Bearing	/	11	Counter flange (Optional accessories)	HT200
6	Mechanical seal	Carbon/SiC/WC	12	Thermal protector	/

Construction and material of SWS stainless steel pump

No.	Spare part	Material	No.	Spare part	Material
1	Cable	YZW	7	Oil seal	NBR
2	Cable gland	SS 304-316L	8	Impeller	SS 304-316L
3	Threading plate	PA66	9	Pump casing	SS 304-316L
4	Motor	Shell 304-316L	10	Basement	SS 304-316L
5	Bearing	/	11	Counter flange (Optional accessories)	SS 304-316L
6	Mechanical seal	Carbon/SiC/WC	12	Thermal protector	/

Technical data and overall dimensions

SW-PRO NO-clogging cut cast iron type(2 Pole)SWS stainless steel same parameter

Model	Size of pump end(DN)	Q	H	Speed	Power	Current	Mad.flow passage	Weight	Overall dimensions (mm)					
	mm								m ³ /h	m	rpm	kW	A	mm
40SW-PRO10-10-0.75	40	10	10	2850	0.75	1.8	20	23	400	300	93	217	312	
40SW-PRO10-15-1.1	40	10	15	2850	1.1	2.6	20	27	415	315	93	217	312	
50SW-PRO10-10-0.75	50	10	10	2850	0.75	1.8	20	23	400	300	93	217	312	
50SW-PRO10-15-1.1	50	10	15	2850	1.1	2.6	20	27	415	315	93	217	312	
50SW-PRO15-10-1.1	50	15	10	2850	1.1	2.6	20	27	415	315	93	217	312	
50SW-PRO15-15-1.5	50	15	15	2880	1.5	3.3	26	35	493	370	103	250	345	
50SW-PRO9-22-2.2	50	9	22	2880	2.2	4.6	26	39	518	390	103	250	345	
50SW-PRO15-20-2.2	50	15	20	2880	2.2	4.6	26	39	518	390	103	250	345	
50SW-PRO15-25-3	50	15	25	2840	3	6.1	23	47	535	405	120	291	386	
50SW-PRO15-32-4	50	15	32	2840	4	7.7	18	52	565	435	120	291	386	
50SW-PRO25-25-4	50	25	25	2840	4	7.7	23	52	565	435	120	291	386	
50SW-PRO15-40-5.5	50	15	40	2940	5.5	10.8	18	86	650	510	123	313	408	
50SW-PRO20-45-7.5	50	20	45	2940	7.5	14.3	18	86	690	550	123	313	408	
50SW-PRO20-55-11	50	20	55	2950	11	21.8	19	100	765	480	128	346	441	
50SW-PRO20-60-15	50	20	60	2950	15	29.3	19	116	805	520	128	346	441	
65SW-PRO15-7-0.75	65	15	7	2850	0.75	1.8	20	23	400	300	93	217	312	
65SW-PRO15-10-1.1	65	15	10	2850	1.1	2.6	20	29	415	315	93	217	312	
65SW-PRO25-10-1.5	65	25	10	2880	1.5	3.3	26	38	493	370	103	250	355	
65SW-PRO25-14-2.2	65	25	14	2880	2.2	4.6	26	42	518	390	103	250	355	
65SW-PRO25-18-3	65	25	18	2840	3	6.1	26	48	535	405	120	291	396	
65SW-PRO40-16-4	65	40	16	2840	4	7.7	26	67	565	435	120	291	396	
65SW-PRO30-25-5.5	65	30	25	2940	5.5	10.8	18	87	650	510	123	313	418	
65SW-PRO30-35-7.5	65	30	35	2940	7.5	14.3	18	87	690	550	123	313	418	
65SW-PRO40-45-11	65	40	45	2950	11	21.8	19	122	765	480	128	346	441	
65SW-PRO40-50-15	65	40	50	2950	15	29.3	19	130	805	520	128	346	441	
80SW-PRO35-7-1.5	80	35	7	2880	1.5	3.3	45	51	505	390	107	276	401	
80SW-PRO40-8-2.2	80	40	8	2880	2.2	4.6	45	55	530	415	107	276	401	
80SW-PRO35-13-3	80	35	13	2840	3	6.1	45	49	560	430	130	295	420	
80SW-PRO50-12-4	80	50	12	2840	4	7.7	45	49	590	460	130	295	420	
80SW-PRO40-22-5.5	80	40	22	2940	5.5	10.8	26	87	660	520	125	325	450	
80SW-PRO40-30-7.5	80	40	30	2940	7.5	14.3	26	87	700	560	125	325	450	
80SW-PRO60-35-11	80	60	35	2950	11	21.8	32	122	775	490	136	340	490	
80SW-PRO60-40-15	80	60	40	2950	15	29.3	32	130	815	530	136	340	490	
100SW-PRO50-10-3	100	50	10	2840	3	6.1	55	50	578	458	136	306	456	
100SW-PRO60-11-4	100	60	11	2840	4	7.7	55	55	608	488	136	306	456	
100SW-PRO65-15-5.5	100	65	15	2940	5.5	10.8	46	92	690	550	143	320	470	
100SW-PRO65-20-7.5	100	65	20	2940	7.5	14.3	46	100	730	590	143	320	470	
100SW-PRO100-25-11	100	100	25	2950	11	21.8	25	125	775	490	136	340	490	
100SW-PRO100-30-15	100	100	30	2950	15	29.3	25	133	815	530	136	340	490	
150SW-PRO100-10-5.5	150	100	10	2940	5.5	10.8	60	112	707	567	150	356	556	
150SW-PRO140-10-7.5	150	140	10	2940	7.5	14.3	60	120	747	607	150	356	556	
150SW-PRO140-15-11	150	140	15	2950	11	21.8	55	128	805	520	168	398	598	
150SW-PRO150-20-15	150	150	20	2950	15	29.3	55	136	845	560	168	398	598	
200SW-PRO180-10-11	200	180	10	2950	11	21.8	70	132	835	550	199	413	670	
200SW-PRO180-15-15	200	180	15	2950	15	29.3	70	140	875	590	199	413	670	

Note: SWS-PRO stainless steel type without DN40 discharge model

SW-PRO NO-clogging cut cast iron type(2 Pole)SWS stainless steel same parameter

Model	Q(m ³ /h)	5	10	15	20	25	30	35	40	45	50	55
40SW-PRO10-10-0.75	H (m)	11.5	10	8	6							
40SW-PRO10-15-1.1		17	15	12.7	9	4						
40SW-PRO15-10-1.1		14.5	12	10	7.5	4.8						
50SW-PRO10-10-0.75		11.5	10	8	6							
50SW-PRO10-15-1.1		17	15	12.7	9	4						
50SW-PRO15-10-1.1		14.5	12	10	7.5	4.8						
50SW-PRO15-15-1.5		18	16.5	15	13.3	11.5	9					
50SW-PRO15-20-2.2		23.3	21.8	20	18.2	16.3	14.2	12.7				
50SW-PRO15-25-3		28.5	27	25	23.2	21.3	19.3	17				
50SW-PRO15-32-4		36	34	32	30	28	26.5	23.6	21			
50SW-PRO25-25-4		31	29.8	28.4	26.5	25	23	21				
50SW-PRO15-40-5.5		42.5	41.7	40	38	36	34	32	30			
50SW-PRO20-45-7.5		49.5	48.5	47	45	43	41	39	37			
50SW-PRO20-55-11		58	57.4	56	55	53	52	50	47.5	45		
50SW-PRO20-60-15		63	62.2	60.7	60	58.3	57	55	53.8	51.7	50	47.5
65SW-PRO15-7-0.75		9.7	9	7	5.3	3.7						
65SW-PRO15-10-1.1		12.8	11.5	10	8	6.5						
65SW-PRO25-10-1.5		15.5	14.4	13.4	11.7	10	8	5.9	3			
65SW-PRO25-14-2.2		17.2	16.7	15.2	14.7	14	13	11.2	9.5	7.6	5.5	
65SW-PRO25-18-3		23	22	20.9	19.6	18	16.5	14.3	12.5	10.2	7.4	
65SW-PRO40-16-4		25.3	24	22.8	21.5	20.2	19	17.5	16.2	14.2	12.6	10.5
65SW-PRO30-25-5.5		31.5	30.5	29	28	26.5	25	23	21.7	19.9	18	16.2
65SW-PRO30-35-7.5		42	41	40	38.7	37.2	35	33	30.7	28	24.7	21
65SW-PRO40-45-11		53	52.5	51.3	50.6	49.5	48	47	45	43.8	42	40.2
65SW-PRO40-50-15		59	57.6	57	55	54.5	52.6	51	50	48	46	44.9

Model	Q(m ³ /h)	10	20	30	40	50	60	70	80	90	100	110
80SW-PRO35-7-1.5	H (m)	10	8.9	7.6	6	4.4	2.5					
80SW-PRO40-8-2.2		12	10.8	9.6	8	6.5	4.6					
80SW-PRO35-13-3		17	15.5	14	12	9.7	6.7					
80SW-PRO50-12-4		21	19.5	17.2	15	12	9	5.5				
80SW-PRO40-22-5.5		30.8	28.2	25	22	17	12.1	7				
80SW-PRO40-30-7.5		37	35	33	30	27.3	24.5	20.5	14			
80SW-PRO60-35-11		42	41.2	40.2	39.7	37.3	35	33	30.6	27.6	23.8	
80SW-PRO60-40-15		47	46.4	45	43.5	42	40	37.7	35	32	28.4	
100SW-PRO50-10-3		15.5	14.2	13	10.8	10	7.5	5.8				
100SW-PRO60-11-4		20.5	19	17.5	16	14	11	8	5			
100SW-PRO65-15-5.5		21.8	21	20	19	18	16.5	14.5	12	8		
100SW-PRO65-20-7.5		25.5	24.5	23.5	22.5	21.5	20.5	19.5	18.5	17	15	12.5

Model	Q(m ³ /h)	20	40	60	80	100	120	140	160	180	200	220	
100SW-PRO100-25-11	H (m)	40	35	30	25	19	12						
100SW-PRO100-30-15		45	40	35	30	24	17						
150SW-PRO100-10-5.5		16.5	15.5	13.7	12	10	8	5.8	3.5				
150SW-PRO140-10-7.5		19	18.3	17	15.5	14	12	10	7.8	5.2			
150SW-PRO140-15-11		27	25	23	21	19	17	15	13	11			
150SW-PRO150-20-15		33	31	29	27.5	25.5	23	21	19	16	13		

Model	Q(m ³ /h)	30	60	90	120	150	180	210	240	270	300	330
200SW-PRO180-10-11	H (m)	18.5	17	15.5	14	12.2	10	7	2			
200SW-PRO180-15-15		23.5	22	20.5	19	17.2	15	13	10	4		

Note: SWS-PRO stainless steel type without DN40 discharge model

Performance cruve

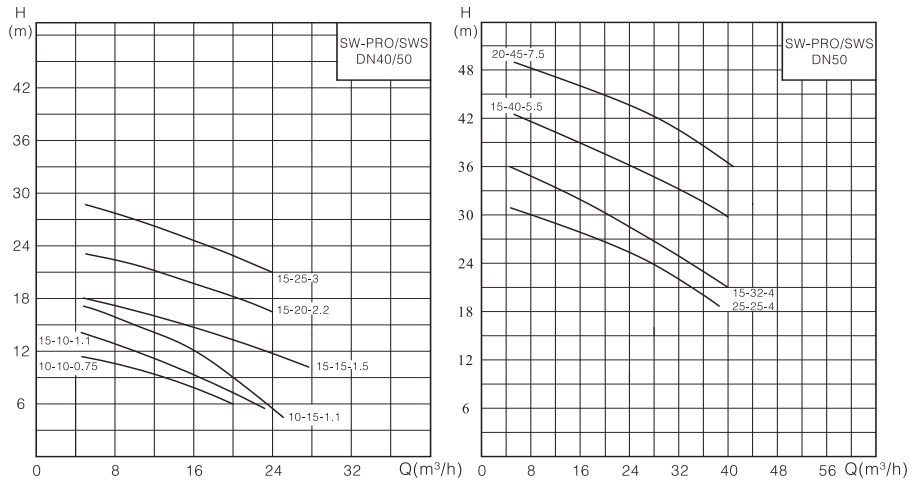

Performance cruve

